

MANHASSET®

The Standard of Excellence Around the World Since 1935.

Instructions for assembly:
Manhasset Short Stand Cart
Model #1920

Tools Required:

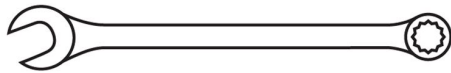

1/2" or 13MM Wrench

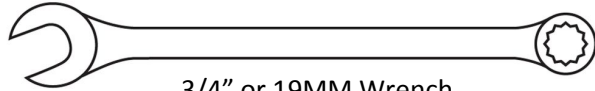

3/4" or 19MM Wrench

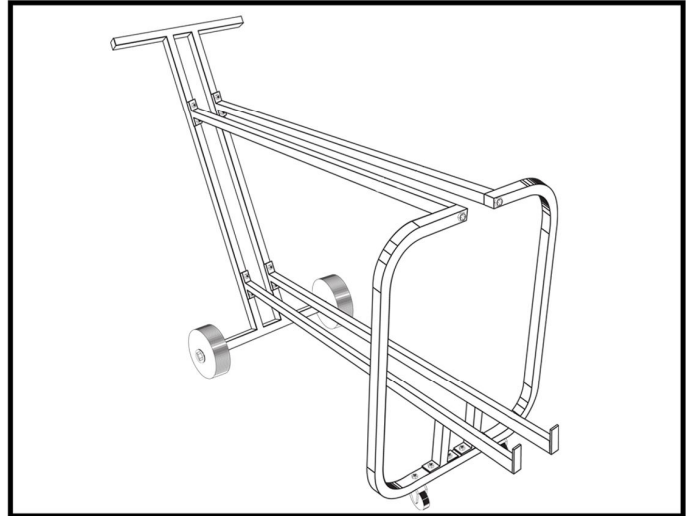

DO NOT TIGHTEN SECURELY UNTIL ALL NUTS AND BOLTS ARE IN PLACE.

1. Before beginning assembly, be sure all parts are present using the parts list on the back of this page. *Do not dispose of any packaging until assembly is complete.*
2. Attach the UPPER and LOWER BARS to the HANDLE FRAME using the 8MM bolts, washers and lock washers as illustrated in the diagram on the back page. At this point, it may be easier to undertake the next couple steps if the unit is turned upside down.
3. Attach the UPPER and LOWER BARS to the END FRAME using the 8MM bolts, flat washers, lock washers and nuts. The vertical extensions (legs) on the LOWER BARS are connected to the END FRAME using (4) bolts, washers and nuts. The UPPER BARS are connected to the END FRAME with lock washers and bolts threaded into the threaded plugs on the end of the upper rail, as illustrated in diagram.
4. With the large bolts, attach the 6" wheels to the HANDLE FRAME axle using a large washer on each side of the wheel. Do not over-tighten; the wheels have to spin freely.
5. Attach the 2 casters to the END FRAME. The threaded post on the caster is connected using the star washer below the square tubing and the flat washer, lock washer and nut above the square tubing.
6. Tighten all nuts and bolts securely on the entire cart and assembly. (If the cart was turned upside down, it should be flipped back.)
7. Install the **PLASTIC RAIL GUARDS**. There are two different sets of rail guards. The guards without cutout notches are to be fitted over the top horizontal rails. The guards with the cutout notches are to be fitted over the lower horizontal rails, with the notched areas lining up with the legs. The installation requires spreading the sides of the guards at one end and pushing them over the horizontal rails – working from one end to the other.
8. For maximum storage when loading the stands onto the cart, be sure to flip the desk all the way over backwards to the storage position as shown at right.

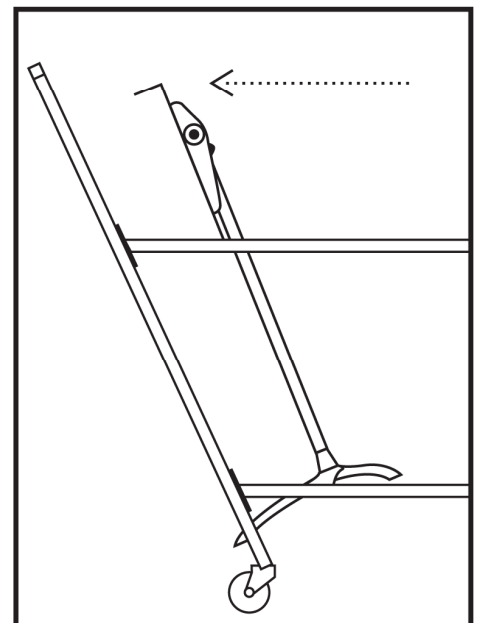

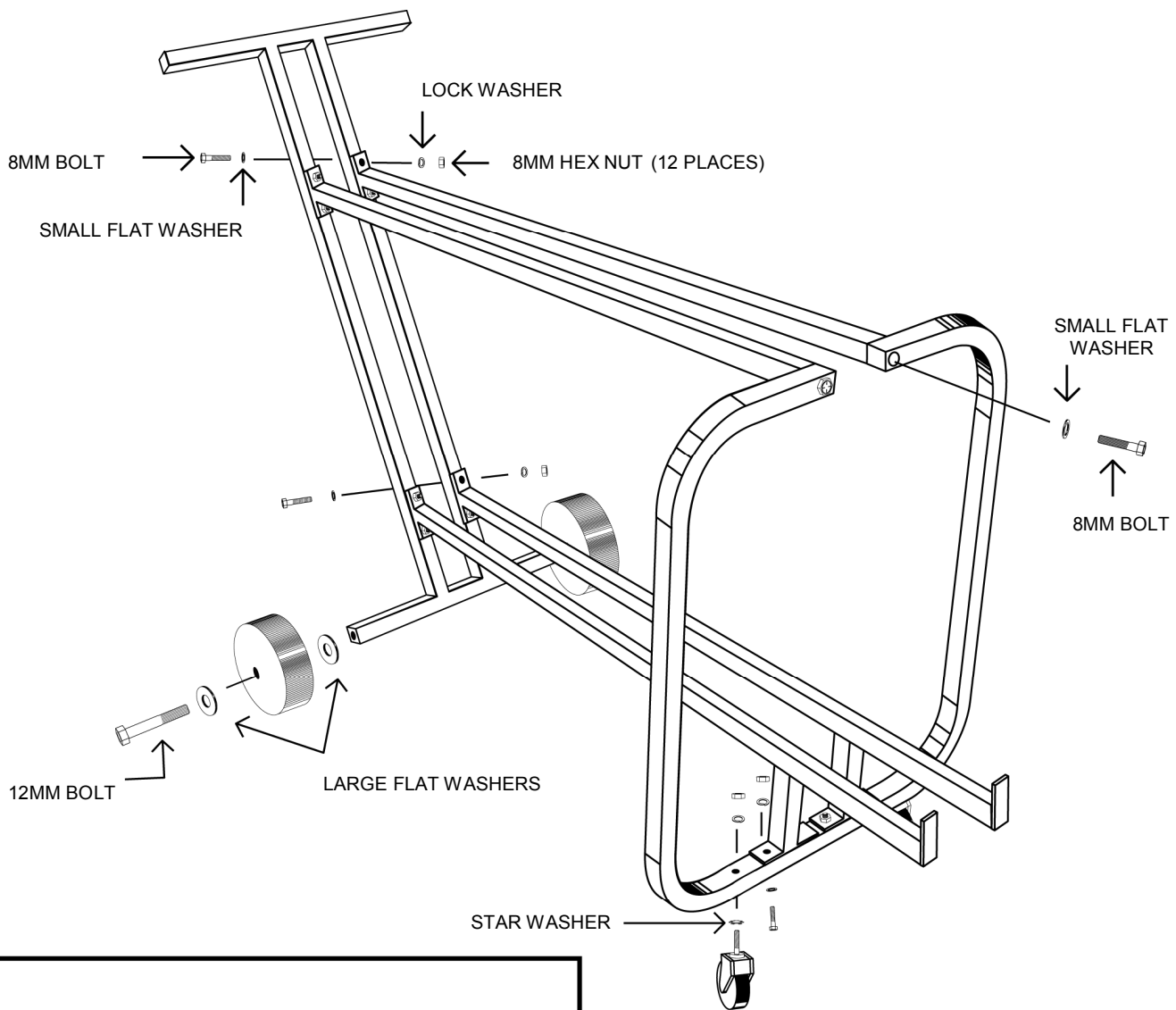

#1943 END FRAME

#1951 HANDLE FRAME

| | | |
|--|-------|-------------------------|
| | #1922 | 12MM AXLE BOLT (2) |
| | #1923 | LARGE WHEEL WASHERS (4) |
| | #78 | 8MM BOLT (14) |
| | #1928 | SMALL FLAT WASHERS (12) |
| | #1929 | LOCK WASHERS (14) |
| | #1930 | 8MM HEX NUTS (12) |

#1939 UPPER BAR (2 PIECES)

#1941 LOWER BAR (2 PIECES)

(Not Pictured)

| | | |
|--|-------|--------------------------------------------------------------------------------------|
| | #1960 | PLASTIC RAIL GUARDS (4) |
| | #1921 | 6" POLYETHELENE WHEEL (2) |
| | #1945 | 3" THREADED STEM CASTER (2) with 1 star washer, 1 flat washer, 1 lock washer & 1 nut |